

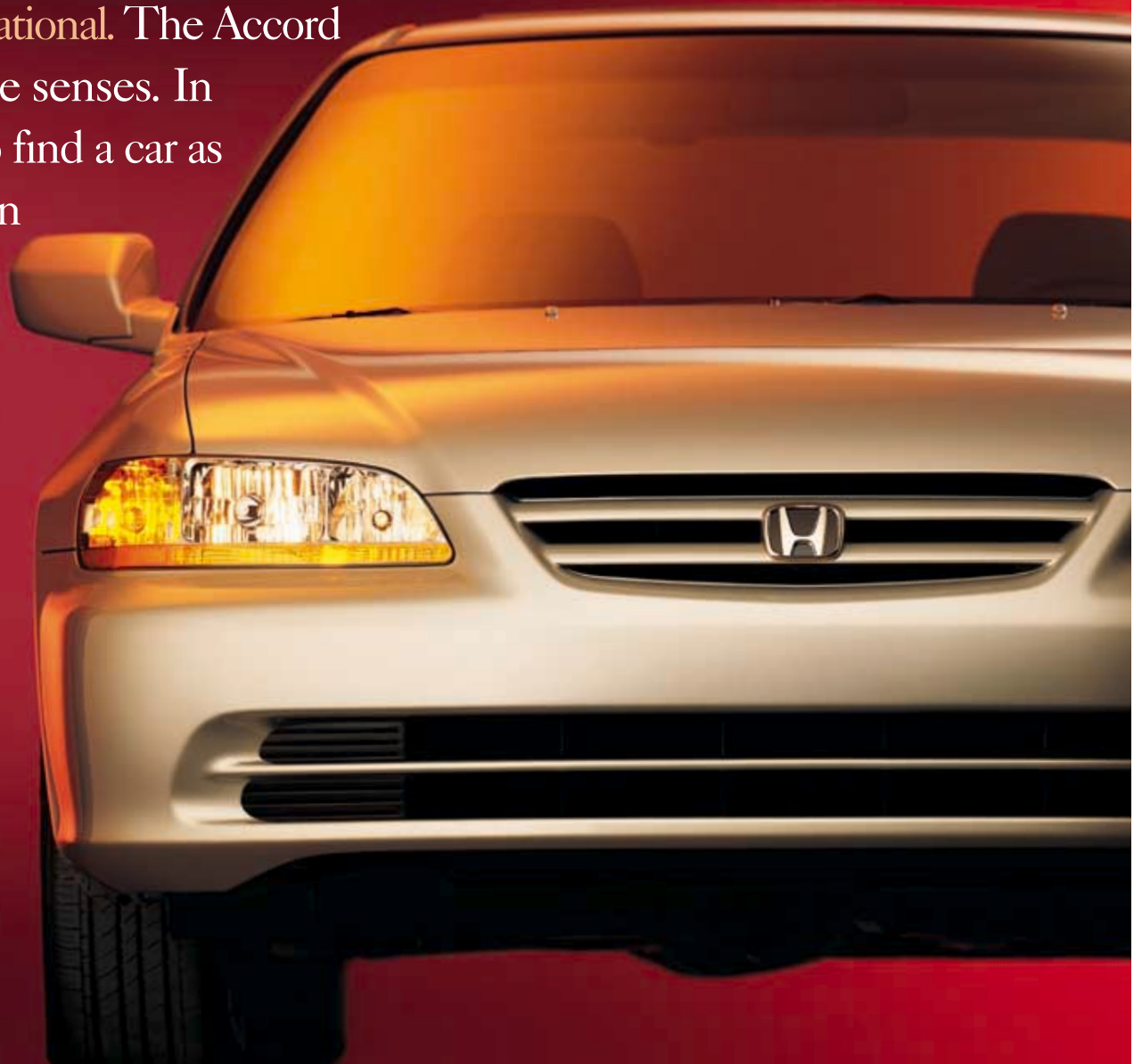

2001
Honda
Accord Sedan

To say the Accord Sedan is a shining example of quality and reliability is a bit of an understatement. However, its virtues far exceed the purely rational. The Accord Sedan is literally a feast for the senses. In fact, you'd be hard-pressed to find a car as complete as the Accord Sedan at any price. All it takes is one drive to understand. Its responsive performance and surefooted handling offer you an exceptionally rewarding driving experience. Add to that an interior that's roomy and luxurious, and you're left with a feeling that's all Honda. And all Accord.



Attraction. *Passion.* Desire.
And that's before you even hit the road.



The Accord Sedan.

Accord EX V-6 Sedan shown in Satin Silver Metallic.

ACCORD DX SEDAN: People love the Accord DX Sedan. It's not surprising when you consider it's got a very lively 135-horsepower, 2.3 liter, 4-cylinder engine. It also includes a sophisticated and responsive 4-wheel double wishbone/multilink suspension. The DX Sedan boasts an incredibly smooth-shifting 5-speed manual transmission. A 4-speed automatic transmission complete with Honda's innovative Grade Logic Control System is also available.

ACCORD LX SEDAN: As you might expect, the Accord LX Sedan includes a host of very impressive features. First, there's the responsive 150-horsepower* VTEC™ engine. Cruise control and power windows, mirrors and door locks are included as well. There's also a 6-speaker AM/FM stereo CD player. And the air-conditioning system includes a micron air-filtration system.

ACCORD EX SEDAN: The heightened luxury is hard to miss in the Accord EX Sedan. Besides everything offered in the LX Sedan, you get a power moonroof with tilt feature, a driver's seat with power height adjustment and adjustable lumbar support, alloy wheels and a security system with remote entry. And there's an AM/FM stereo cassette complete with a 6-disc in-dash CD changer. An anti-lock braking system (ABS) and dual side airbags are also included.

Meet the Accord Sedan family. They'll all make you feel welcome.



ACCORD LX V-6 SEDAN: For those who opt for more power, the Accord LX V-6 Sedan is the way to go. Its 200-horsepower, 3.0 liter, 24-valve, VTEC V-6 engine is sure to please any driving enthusiast. The LX V-6 includes a Traction Control System (TCS) for enhanced traction on slippery surfaces. For your comfort, the air conditioner includes a micron air-filtration system. There's an 8-way power-adjustable driver's seat. And a 6-speaker AM/FM stereo CD player is included. For added protection, dual side airbags are standard.



ACCORD EX V-6 SEDAN: Luxury appointments abound in the EX V-6 Sedan. Leather-trimmed seats are sure to pamper you. There's also automatic climate control with a micron air-filtration system. In addition, the sound system includes a cassette player and 6-disc in-dash CD changer. Steering wheel-mounted audio controls come standard, as do a power moonroof and a 4-way power passenger seat. A security system with remote entry and a HomeLink® remote system† are also included.



Prepare to be stared at.

Accord EX V-6 Sedan shown in Nighthawk Black Pearl.



Can your living room do all this?



Accord EX V-6 Sedan interior shown in Ivory leather.

A lot of care and thinking goes into every Accord we make. Honda engineers are constantly striving for and **finding exciting, new and innovative ways** to make things even better, more efficient and ergonomic. Let's take the leather-wrapped steering wheel on the EX V-6 and EX with leather, for example. Audio controls have been thoughtfully mounted right on it. This simple feature allows you to change stations or adjust the volume while keeping your hands firmly on



the wheel and your eyes on the road. The instrument panel is well-thought-out, too. It's been angled so that the large, easy-to-use knobs and buttons are easy to see and reach. And for added convenience, the center console has two built-in storage bins. Two handy beverage holders in the front seat are a welcome relief during long road trips. All of which are intended to make your time spent behind the wheel of the Accord Sedan that **much more enjoyable.**



From the moment you sit in the luxurious and roomy Accord Sedan, an amazing thing happens. You realize very quickly that **your comfort is our utmost priority**. Let's start with the seats. They're wide, supportive and exceptionally comfortable. And since driver comfort is of primary importance, we've included an 8-way power-adjustable driver's seat on V-6 models and the EX with leather interior. And on the EX V-6, the front passenger seat is equipped with a 4-way power adjustment. Your listening pleasure has been taken into account as well. That's why an AM/FM stereo with CD sound system is standard on the LX and LX V-6 models. And on the EX and EX V-6 models, we've combined a cassette player with a very entertaining 6-disc in-dash CD changer.

Accord EX Sedan interior shown in Lapis fabric.



Talk about a custom fit. This **8-way power-adjustable driver's seat**, on both V-6 models and EX with leather, lets you tailor your Accord Sedan to fit practically like a glove.



Thanks to the **steering wheel-mounted audio controls**, you can easily adjust your stereo without taking your hands off the wheel or your eyes off the road. (Standard on the EX V-6 and EX w/leather.)



To maximize your comfort, the Accord EX V-6 comes with an **automatic climate control system**. You simply adjust your preferred setting and it automatically maintains your preselected temperature.

And since we want you to stay calm, cool and collected, an air-conditioning system comes standard on all LX and EX models. It even includes a micron air-filtration system that's capable of filtering out unwanted allergens and dust. You'll breathe a lot easier. And on the EX V-6, an automatic climate control system has also been included. Other thoughtful features on the LX, EX and V-6 models include a sunglasses holder, map lights and a large storage bin in the center console. Of course, cruise control and power door locks and windows are standard on all LX, EX and V-6 models, as is the Immobilizer Theft-Deterrent System (including DX). In this ingenious system, the ignition key contains an electronic "fingerprint" that renders the car virtually incapable of starting without it. And since we want to do everything we can to ensure that your arrival home is as pleasant as your trip, the Accord EX V-6 Sedan includes the HomeLink® remote system. It actually allows you to activate your home's automatic garage door and gate openers or interior lights with just the simple touch of a button. The Accord Sedan. Prepare to be pampered.



Got odd-sized cargo? No problem in the Accord Sedan. Simply fold down the **rear seat pass-through****. Plus the two beverage holders are sure to be a much appreciated feature for your rear-seat passengers (on all models except DX).



Conveniently located in the driver's side door, the **illuminated power window control** was designed to make finding and identifying your desired button easy at night (standard on LX, EX and V-6 models).

Honda is, first and foremost, an engine-building company. Our dedication to engineering excellence is evident in every vehicle we make. In the Accord Sedan's case, the goal was to build an elegant, roomy car with a focus on performance. This was achieved through powerful engines, a refined suspension system and a well-thought-out cabin. The Accord continues

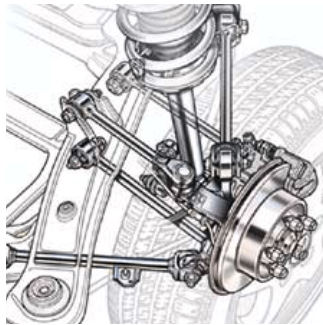

to be a benchmark for the industry by demonstrating Honda's commitment to progress through advanced technology. The Accord was the very first gasoline-powered production car to be certified as an Ultra-Low-Emission Vehicle (ULEV) in the U.S. And yet, we never forget the attributes we've built our reputation on. Unsurpassed reliability, durability and quality.



Accord's smooth and powerful aluminum 200-hp, 3.0 liter, 24-valve **V-6 engine** features Honda VTEC technology for maximum fuel efficiency^{††} and excellent throttle response.



To minimize vibration, Accord 2.3 liter, 4-cylinder engines feature an innovative Honda-designed **second-order balance system**. The system contributes to the Accord's remarkable smoothness.

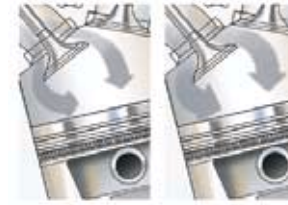

Honda's **variable valve timing and lift electronic control (VTEC)** technology and advanced 4-valve-per-cylinder pentroof combustion chambers maximize combustion efficiency and performance.



Accord EX V-6 Sedan shown in Dark Emerald Pearl.

Whether it's our eight-hundred-and-fifty-horsepower Champ-Car V-8 racing engine, or the Accord's smooth and powerful V-6 and 4-cylinder engines, more than fifty years of Honda engine-building expertise ensure they are perfectly suited for the job at hand.



The Accord engines owe their **power, reliability and efficiency** to their high degree of technical sophistication. For example, the 200-hp, 3.0 liter V-6 and 150-hp, 2.3 liter inline-4 utilize many advanced friction-reduction techniques found on our racing engines. Single overhead camshafts save space, and free-breathing pentroof combustion chambers and VTEC variable valvetrains help extend power, improve fuel efficiency^{††} and help lower emissions. All Accords are certified as Low-Emission Vehicles (LEV) or better. Special liquid-filled active engine mounts, a second-

order balance system (2.3 liter engine) and a 60-degree V angle (3.0 liter engine) minimize vibration. And no major tune-ups[‡] are required for the first 105,000 miles of operation. The Accord's transmissions show the same **innovative engineering** as its engines. Its electronically controlled 4-speed automatic transmission uses a special Grade Logic Control System that automatically downshifts and holds the appropriate gear on hills, thereby eliminating any "gear hunting."



Select Accord EX sedans[∞] feature **an exclusive lean-burn in-line 4-cylinder VTEC engine**. It meets Super Ultra-Low-Emission Vehicle (SULEV) standards under California's tough regulations.

[‡]Does not apply to fluid and filter changes. See your owner's manual for details.



Scenery is better the closer you get.



Honda Progressive Valve shock absorbers automatically adjust to road and driving conditions, providing softer damping over bumps and firm control when cornering. HPV shock absorbers also help improve stability at highway speeds.



Accord's **multilink rear suspension**, HPV shock absorbers and a special subframe help absorb bumps without compromising stability. Accord sedans feature front and rear (front only on DX) stabilizer bars for taut, responsive cornering.

One of the most distinctive features of the Accord Sedan is the way it delivers a quiet, comfortable ride without sacrificing either responsive handling or excellent road feel. The secret lies in its sophisticated 4-wheel double wishbone/multilink suspension. This unique suspension system utilizes special upper and lower suspension links that accurately control wheel movement so that the tires can maintain optimum contact and adhesion with the road surface throughout the wheel and suspension's entire range of movement. As a result, the Accord exhibits precise handling and control whether negotiating a curve, driving at highway speeds or hard braking. The Accord owes its exceptionally comfortable ride to the same 4-wheel double wishbone/multilink system. Here,

the suspension links more effectively isolate the wheels from the body, so the shock absorbers and springs can efficiently soak up bumps, dips and other road-surface imperfections. In addition, special compliance bushings at the suspension's pivot points and a unique linkage system in the rear suspension take the harshness out of sharp impacts, such as potholes and breaks in the pavement. The reason the Accord's ride is so quiet is its highly rigid body-and-frame construction, combined with rubber-isolated subframes for the suspension, and the extensive use of high-tech noise- and vibration-damping materials throughout the body. A smooth, quiet ride and precise handling—there's no need to sacrifice one for the other; the Honda Accord's suspension and chassis are designed to give you both.



Noise, vibration and harshness are minimized throughout the Accord Sedan. Road and engine vibration are insulated from the passenger cabin by specially designed, rubber-isolated subframes. In addition, the body is insulated against road noise.

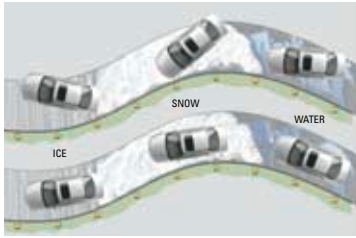

The Accord's **Traction Control System (TCS)** enhances traction and vehicle control by helping to prevent wheelspin when starting out on slippery surfaces.



Accord EX Sedan shown in Eternal Blue Pearl.



Supplemental restraint systems include dual-stage driver's and front passenger's airbags (SRS). The EX and V-6 models feature standard dual side airbags.

Advanced safety systems found in the Accord include an impact-absorbing body with front and rear crush zones, with side-impact protection in the doors, roof, floor and cowl structures.



The Accord has a lengthy complement of safety features to help keep you and your family safe. In addition to **meeting or exceeding all federal standards**, the Accord's body and interior are designed to help protect the driver and passengers in a full-frontal, offset-frontal, side or rear impact. Accords have 3-point seat belts for the driver and all passengers. The passenger cabin is surrounded by reinforced body elements, with steel beams in the doors and jambs serving as parts of a comprehensive safety cage. In front, dual-stage driver's and passenger's airbags (SRS)[‡] are standard. The EX and V-6 models feature standard dual side airbags. The rear seat has a LATCH (Lower Anchors and Tethers for Children) child-seat mounting system. All V-6 models feature a standard Traction Control System (TCS) for **increased control on slippery roads**. Also, a 4-wheel double wishbone/multilink suspension, ventilated front disc brakes (4-wheel discs with an anti-lock braking system on EX and V-6 models) and rack-and-pinion steering help to keep you in control.

[‡]Honda reminds you and your passengers to always buckle up.

Accord 4-cylinder EX and LX/EX V-6 sedans feature 4-wheel disc brakes with an **anti-lock braking system (ABS)**. ABS allows the driver to retain steering control under maximum braking.





For years, **Honda has led the industry** in reducing the impact automobiles have on



the environment. Proving that it can be done with little sacrifice to performance. In 1975, we introduced the innovative Civic CVCC, the first car to

pass the federal Clean Air Act standards without the use of a catalytic converter.

Ever since, our engineers have pushed the limits of design. When California's standards for Low-, Ultra-

Low- and Super Ultra-Low-Emission Vehicles (LEV, ULEV and SULEV) were introduced over the past seven years, a Honda was the first gasoline-powered car to meet each one. In fact, we have met these government standards before they



were mandatory. While all Civics are now ULEV or better, every Honda does its part. From the natural-gas Civic GX, the cleanest internal combustion production-engine vehicle ever built, to the LEV-rated 240-hp S2000 roadster. With our track

record, it's only fitting that we would



be the first to introduce a gasoline-electric-powered hybrid car in the United States: the Insight. This ultra-low-emission vehicle

was the first car to receive the **Excellence in Environmental Engineering Award** from the Sierra Club. Honda will continue to lead the way in providing you with some of the most advanced and cleanest vehicles on the road today.



When you buy a new Honda, a team of **dedicated professionals** is standing by to assist you. Your dealer can help personalize



your Honda with a wide assortment of Genuine Honda Accessories. Have them installed at the

time of purchase and they're covered by the 3-year/36,000-mile limited warranty.**

And our Honda-trained technicians are available to help you take care of your new car. With their vast **expertise and knowledge**,

they'll be able to help keep your vehicle in excellent condition. After all, no one knows your Honda better. If you'd like additional information, call us at 1-800-33-HONDA.

Or visit our Web site at honda.com. If you're looking for quality, dependability and exceptional service, it's time for a Honda.

HONDA Finance

If you want quality service and dependable nationwide support, turn to **American Honda Finance Corporation**. They can assist you with your next purchase of a Honda automobile or product.

HONDA Care

Honda Care is a comprehensive, affordable vehicle and travel protection plan that is backed by Honda reliability, service and parts. Check with your dealer for additional information.



Your new Accord will look even more sporty and sleek with a **rear wing spoiler and 9-spoke alloy wheels**. The spoiler, which is color-matched to original factory specifications, includes a brakelight. And the finely crafted, handsome alloy wheels come in a variety of styles. You can choose from several other available wheel options. Together, the wheels and spoiler look great and are the ideal way to personalize your Accord.

Other available accessories:

- Audio Systems
- Keyless Remote Entry/Security System
- Fog Lights
- Splash Guards
- Gold Emblem Kit
- Fenderwell Trim
- Wood-Grain Trim Kit
- Wood-Grain Steering Wheel
- Color-Matched Door Edge Guards
- Nose Mask (Half and Full)
- Car Cover
- Leather Shift Knob
- Leather Steering Wheel Cover

Visit your Honda dealer or honda.com for a complete list of accessories.

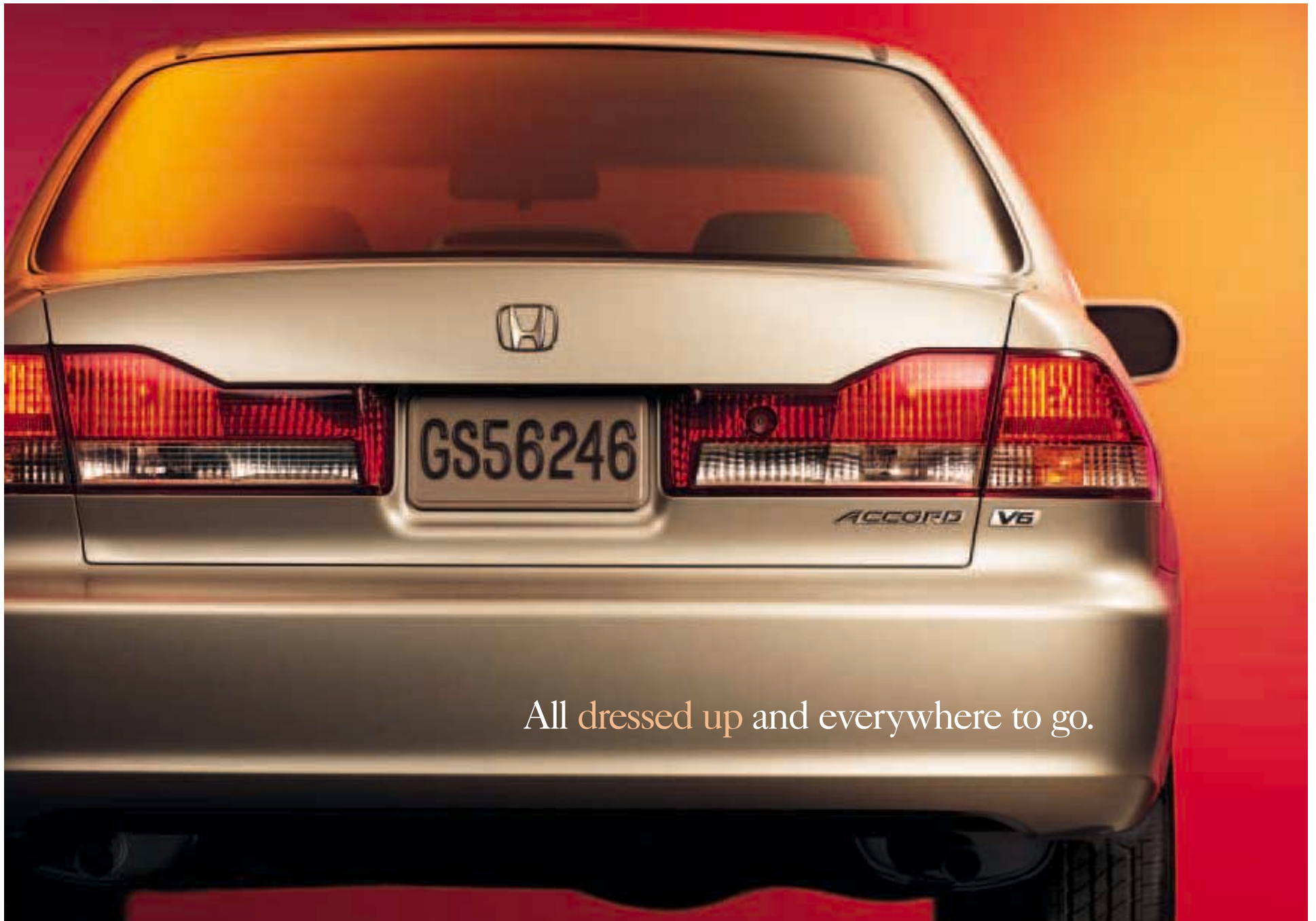

All dressed up and everywhere to go.

2001
Honda
Accord
Sedan

Specifications
and Features

Engine	DX	LX	EX	LX V-6	EX V-6
Type: Aluminum Alloy	In-Line 4-Cyl.	In-Line 4-Cyl.	In-Line 4-Cyl.	V-6	V-6
Displacement (liters)	2.3	2.3	2.3	3.0	3.0
Horsepower @ rpm (SAE net)	135 @ 5400	150 @ 5700*	150 @ 5700**	200 @ 5500	200 @ 5500
Torque (lb.-ft. @ rpm)	145 @ 4700	152 @ 4900*	152 @ 4900**	195 @ 4700	195 @ 4700
Compression Ratio	8.8:1	9.3:1	9.3:1	9.4:1	9.4:1
Valve Train: SOHC	16-Valve	16-Valve VTEC™	16-Valve VTEC™	24-Valve VTEC™	24-Valve VTEC™
Fuel System: Multi-Point Fuel Injection	•	•	•	•	•
Ignition System: Electronic w/Immobilizer	•	•	•	•	•

Drivetrain	DX	LX	EX	LX V-6	EX V-6
Type: Front-Wheel Drive	•	•	•	•	•
Manual Transmission: 5-Speed	•	•	•		
Automatic Transmission w/Grade Logic Control System: 4-Speed (available)	•	•	•	STD	STD
Final Drive Ratio (MT/AT)	4.06/4.46	4.06/4.46	4.06/4.46	NA/4.20	NA/4.20

Body/Suspension/Chassis	DX	LX	EX	LX V-6	EX V-6
Body Type: Unit Body	•	•	•	•	•
Suspension: 4-Wheel Double Wishbone/Multi-link	•	•	•	•	•
Stabilizer Bar (mm, front/rear)	23.0/NA	26.5/16.0	26.5/16.0	27.2/16.0	27.2/16.0
Variable-Assist Power Rack-and-Pinion Steering	•	•	•	•	•
Turning Diameter, Curb-to-Curb (ft.)	36.4	36.4	36.4	36.4	36.4
Front Disc/Rear Drum Brakes	•	• (ABS Available)	•	•	•
4-Wheel Disc Brakes w/Anti-Lock Braking System (ABS)			•	•	•
Traction Control System			•	•	•
Wheels	14" w/Full Covers	15" w/Full Covers	15" Alloy	15" w/Full Covers	15" Alloy
Tires: All-Season	P195/70 R14	P195/65 R15	P195/65 R15	P205/65 R15	P205/65 R15

Exterior Dimensions	DX	LX	EX	LX V-6	EX V-6
Wheelbase (in.)	106.9	106.9	106.9	106.9	106.9
Length (in.)	189.4	189.4	189.4	189.4	189.4
Height (in.)	56.9	56.9	56.9	57.3	57.3
Width (in.)	70.3	70.3	70.3	70.3	70.3
Track (in., front/rear)	61.2/60.4	61.2/60.4	61.2/60.4	61.2/60.4	61.2/60.4
Curb Weight (lbs., MT/AT)	2943/3009	3031/3097	3075/3142	NA/3274	NA/3329

Interior Dimensions	DX	LX	EX	LX V-6	EX V-6
Headroom (in., front/rear)	40.0/37.6	40.0/37.6	38.5/36.5	40.0/37.6	38.5/36.5
Legroom (in., front/rear)	42.1/37.9	42.1/37.9	42.1/37.9	42.1/37.9	42.1/37.9
Shoulder Room (in., front/rear)	56.9/56.1	56.9/56.1	56.9/56.1	56.9/56.1	56.9/56.1
Hiproom (in., front/rear)	54.9/54.1	54.9/54.1	54.9/54.1	54.9/54.1	54.9/54.1
Cargo Volume (cu. ft.)	14.1	14.1	14.1	14.1	14.1
Passenger Volume (cu. ft.)	101.7	101.7	98.3	101.7	98.3

Exterior/Interior Colors	DX	LX	EX	LX V-6	EX V-6
Eternal Blue Pearl/Lapis	•	•	• (Available w/Leather)		
Satin Silver Metallic/Quartz	•	•	• (Available w/Leather)	•	Leather
Firepepper Red Pearl/Ivory			• (Available w/Leather)	•	Leather
Naples Gold Metallic/Ivory		•	• (Available w/Leather)	•	Leather
Dark Emerald Pearl/Ivory		•	• (Available w/Leather)	•	Leather
Taffeta White/Lapis	•	•			
Taffeta White/Ivory			• (Available w/Leather)	•	Leather
Nighthawk Black Pearl/Quartz	•	•	• (Available w/Leather)	•	Leather

Exterior Features	DX	LX	EX	LX V-6	EX V-6
Power Moonroof w/Tilt Feature			•		•
Integrated Rear-Window Antenna	•	•	•	•	•
Dual Manual Remote-Operated Mirrors	•				
Body-Colored Dual Power Mirrors		•	•	•	•
Alloy Wheels		Accessory	(w/ABS)	•	Accessory
Multi-Reflector Halogen Headlights	•	•	w/Auto-Off	•	w/Auto-Off
Security System w/Remote Entry			Accessory	•	Accessory
Body-Colored Body Side Molding	Black	•	•	•	•
Body-Colored Impact-Absorbing Bumpers	•	•	•	•	•

Interior Features	DX	LX	EX	LX V-6	EX V-6
Air Conditioning	Accessory	•	•	•	Automatic
Power Windows w/Auto-Down Driver's Window		•	•	•	•
Power Door Locks		•	•	•	•
AM/FM Stereo w/Cassette		w/2 Speakers			
AM/FM Stereo w/CD Player			w/6 Speakers		w/6 Speakers
AM/FM Stereo w/Cassette/6-Disc CD Changer			w/6 Speakers		w/6 Speakers
Cruise Control		•	•	•	•
Leather-Trimmed Seats and Door Panel Inserts				Available	•
Leather-Wrapped Steering Wheel	Accessory	Accessory	(w/Leather Trim)	Accessory	•
Driver's and Front Passenger's Airbags (SRS)	•	•	•	•	•
Dual Side Airbags	Available	Available	•	•	•
Front 3-Point Seat Belts w/Automatic Tensioning System	•	•	•	•	•
Adjustable Front Seat Belt Anchors	•	•	•	•	•
Lower Anchors and Tethers for Children (LATCH)	•	•	•	•	•
HomeLink® Remote System†				•	•
Driver's Seat w/8-Way Power Adjustment			(w/Leather Trim)	•	•
Passenger's Seat w/4-Way Power Adjustment					•
Driver's Seat w/Power Height Adjustment		Manual	•		
Driver's Seat Adjustable Lumbar Support			•		•
Fold-Down Rear Seat Center Armrest		•	•	•	•
Fold-Down Rear Seatback w/Lock	•	•	•	•	•
Trunk Pass-Through w/Lock	•	•	•	•	•
Beverage Holders, Front and Rear	Front	•	•	•	•
Steering Wheel-Mounted Audio Controls			(w/Leather Trim)		•
Center Console Armrest w/Storage Compartments	•	•	•	•	•
Adjustable Steering Column	•	•	•	•	•
Sunglass Holder		•	•	•	•
Rear Window Defroster w/Timer	•	•	•	•	•
Lockable Glove Compartment w/Light	•	•	•	•	•
Remote Fuel Filler Door Release	•	•	•	•	•
Remote Trunk Release w/Lock	•	•	•	•	•
Electronic Remote Trunk Release			•		•
Maintenance Interval Indicator		•	•	•	•
2-Speed/Variable Intermittent Windshield Wipers	Non-Variable	•	•	•	•
Dual Front Illuminated Vanity Mirrors	Non-Illuminated	•	•	•	•
Map Lights		•	•	•	•
Floor Mats	Accessory	Accessory	•	•	•

EPA Mileage Estimates†/Fuel Capacity	DX	LX	EX	LX V-6	EX V-6
5-Speed Manual (City/Highway)	25/32	26/32	26/32		
4-Speed Automatic (City/Highway)	23/30	23/30	23/30	20/28	20/28
Fuel (gal.)	17.1	17.1	17.1	17.1	17.1

*ULEV-rated @ 148 hp/148 lb.-ft. (Available in California and parts of the Northeast.) †HomeLink® is a registered trademark of Prince Corporation, a wholly owned subsidiary of Johnson Controls.™ **Honda reminds you to properly secure items stored in the trunk pass-through. ††Mileage figures shown for comparison only. Actual mileage may vary. ‡SULEV-rated @ 145 hp/144 lb.-ft. on EX (AT) with Leather. (Available only in California.) ***3-Year/36,000-Mile Limited Warranty: Ordinary maintenance or adjustments, parts subject to normal wear and replacement, and certain items are excluded. See your Honda dealer for the terms and conditions of this limited warranty. Always use seat belts and appropriate child seats. Children are safest in the rear seat. Some features mentioned herein are not available in all areas. See your Honda dealer for details. California version differs slightly due to emission standards. Some vehicles may be shown with optional equipment. Available=Optional. NA=Not applicable. Specifications, features, illustrations and equipment shown in this brochure are based upon the latest available information at the time of printing. Although descriptions are believed correct, accuracy cannot be guaranteed. American Honda Motor Co., Inc., reserves the right to make changes at any time, without notice or obligation, in colors, specifications, accessories, materials and models. ©2000 American Honda Motor Co., Inc.



Accord Sedan



Accord Coupe



Civic Sedan



Civic Coupe



S2000



Prelude



Odyssey



Passport



CR-V



Insight



HONDA

honda.com

1-800-33-HONDA